

附屬品介紹

標準附屬品

1. 濕式剎車離合器/複合式剎車離合器
2. 油壓式超負荷裝置
3. 電動黃油潤滑裝置(LGN-80~LGN-260)
4. 滑塊及模具平衡裝置
5. 電動式滑塊調整裝置(LGN-45~LGN-260)
6. 模高指示器
7. 曲軸角度指示器
8. 電子式計數器
9. 防震腳
10. 維護工具

特別附屬品

1. 變頻器/無段變速馬達
2. 光電式安全裝置
3. 氣壓式模墊
4. 滑塊頂料裝置
5. 腳踏操作器
6. 自動送料軸端
7. 快速換模裝置
8. 負荷顯示器
9. 自動化機械手
10. 自動移送裝置

STANDARD ACCESSORIES

1. Wet clutch & brake/Combined clutch
2. Hydraulic overload protector
3. Electrical grease lubrication system(LGN-80~LGN-260)
4. Slide & die balancer
5. Electrical slide adjustment device(LGN-45~LGN-260)
6. Die height indicator
7. Crank angle indicator
8. Preset counter
9. Rubber mounts
10. Maintenance tool

OPTIONAL ACCESSORIES

1. Inverter/Variable speed motor
2. Photoelectric safety device
3. Pneumatic die cushion
4. Slide knockout device
5. Foot pedal switch
6. Power take off shaft
7. Quick die change system(Q.D.C.)
8. Load monitor
9. Robot of automatism
10. Automatic transfer device



立興陳機械



立興陳機械

立興陳機械廠股份有限公司
LI HSING CHEN MACHINE TOOL CO., LTD.

總公司 / 新北市土城區土城工業區民權街8號

Head Office & Factory/

No 8, Min Chuan St., Tu Cheng Industrial Zone,
Tu Cheng Dist, New Taipei City, Taiwan

Tel:886-2-2267-1118(Rep.) Fax:886-2-2267-1277

http://www.lihsingchen.com

E-mail:lihsingc@ms15.hinet.net

廣東廠 / 廣東省佛山市南海區羅村佛羅路段沙布壘工業路2號

Guangdong Factory/

No.2, Sabulang Ind.Road, Foluo Sec., Luocun,
Nanhai Area, Foshan City, Guangdong Province, China

Tel:(0757)86418001~2 Fax:(0757)86418003

E-mail:taixin2005@126.com

AGENTS:

Catalog No.2017

MACHIN

LGN 超強力精密沖床

SUPER HEAVY DUTY PRECISION PRESSES SERIES LGN 25~260 TONS



立興陳機械

LI HSING CHEN

www.lihsingchen.com

超強力精密沖床 SERIES LGN25~260 TONS

▶ 本機特點

- 台身採超強力鋼架結構，經消除內應力熱處理，鋼性特佳。
- 滑塊採用高級鑄鐵一體成型，強度佳，超強之六面導路，可永久保持精度。
- 曲軸採用高級合金鋼，並經特殊處理，強度特佳。
- 油壓超負荷保護裝置，確保機器壽命精度；二度落防止裝置，確保操作之安全。
- 使用雙閥電磁閥，動作確實、安全性高。
- 智慧性設計，可搭配各種自動化裝置。
- 精度符合國家標準(CNS)一級以上。

- Machine body adapts super-strong steel body structure, eliminate internal stress by heat treatment, and the steel is particularly good.
- Slider adapts high quality cast iron body shape, has good strength. It has super-conductivity of the six surfaces and can maintain permanent accuracy.
- High alloy steel crankshaft with special treatment, particularly good in strength.
- Hydraulic overload protection device to ensure the life of the machine precision; second drop down prevention device, to ensure the safety of operation.
- Using double solenoid valve, precise action with high security.
- Intelligent design, can be used with a variety of automated devices.
- Precision conforms to number one national standards (CNS) level or above.



1. 曲軸角度指示器
Crank angle indicator

2. 特厚壁板，剛性特佳。
Special thick plate and the rigid is particularly good

3. 模高指示器
Die height indicator

4. 電器控制箱
Electrical control box

5. 六面長型導軌
Six surfaces long type guide rail

6. 油壓超負荷裝置
Hydraulic overload device

7. 光電式安全裝置(特別附屬品)
Photoelectric safety devices (specially accessories)

8. 氣壓式模墊(特別附屬品)
Pneumatic die cushion (specially accessories)

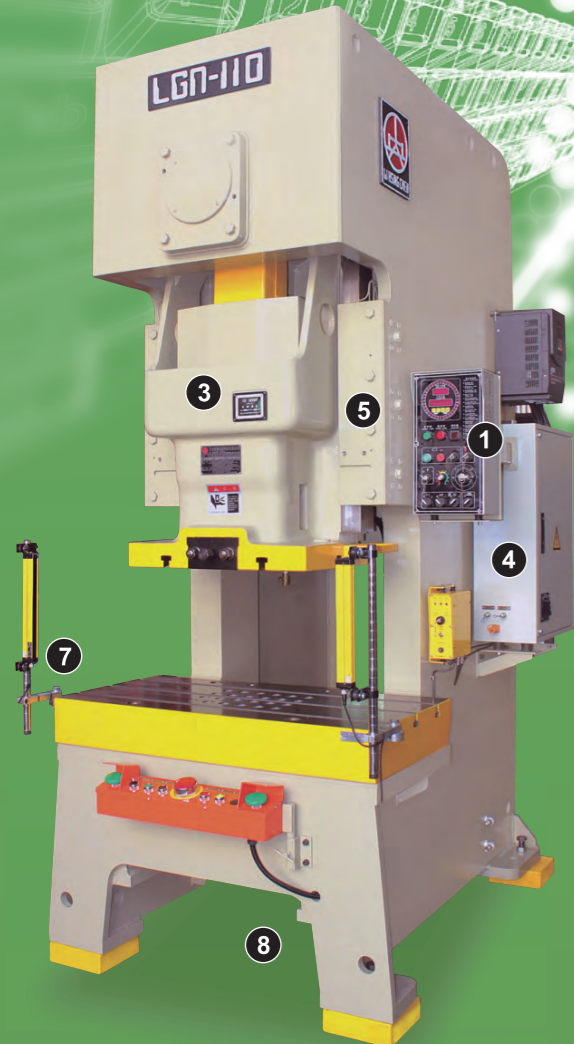

▶ 功能介紹

➡ 雙聯閥電磁閥
Double solenoid valve

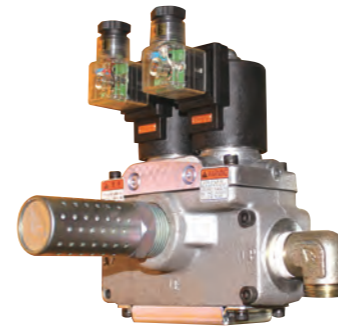

確保沖床機械安全操作而設計，有效避免離合器異常動作。
To ensure the safe operation of punching machine to effectively prevent malfunction clutch.

➡ 油壓式超負荷安全裝置
Hydraulic overload safety device

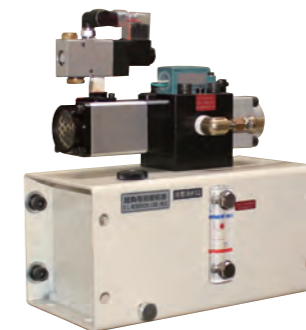

遇有超負荷情況時，滑塊運轉立即停止，確保機台及模具安全。
In the event of overload conditions, the slide stop operation immediately to ensure the safety of machine and mold.

➡ 電動黃油潤滑裝置
Electric grease lubrication device



自動定時潤滑裝置，確保機台運轉順暢。
Automatic lubrication device regularly to ensure smooth running of the machine.

➡ 操作控制箱
Operation control box



人性化設計，具備簡易指示顯示，可輕易排除異常問題。
Humanized design, with simple instructions and can easily eliminate abnormalities.

➡ 操作盤
Operation panel



符合安全之設計，配合簡易操作符號，使操作者更順手。
Meet with safety design, together with easy operation symbols to make the operator more comfortable.

➡ 簡易滑塊調整裝置 (LGN-25)
Simple slide adjustment device



調整容易，手動調模裝置附0.1mm指示器。
Easy to adjust, manual adjustment mode attached with 0.1mm indicator device.

➡ 電動模高調整裝置 (LGN-45~LGN-260)
Electric die height adjusting device



採用電動式模高調整裝置，並裝有上下限自動控制開關，最小調整量能達0.1mm精確位置。
With electric die height adjusting device, and equipped with upper and lower limit control switch, the minimum adjustment to the exact location of up to 0.1mm.

▶ 外型尺寸圖 (LGN-25)

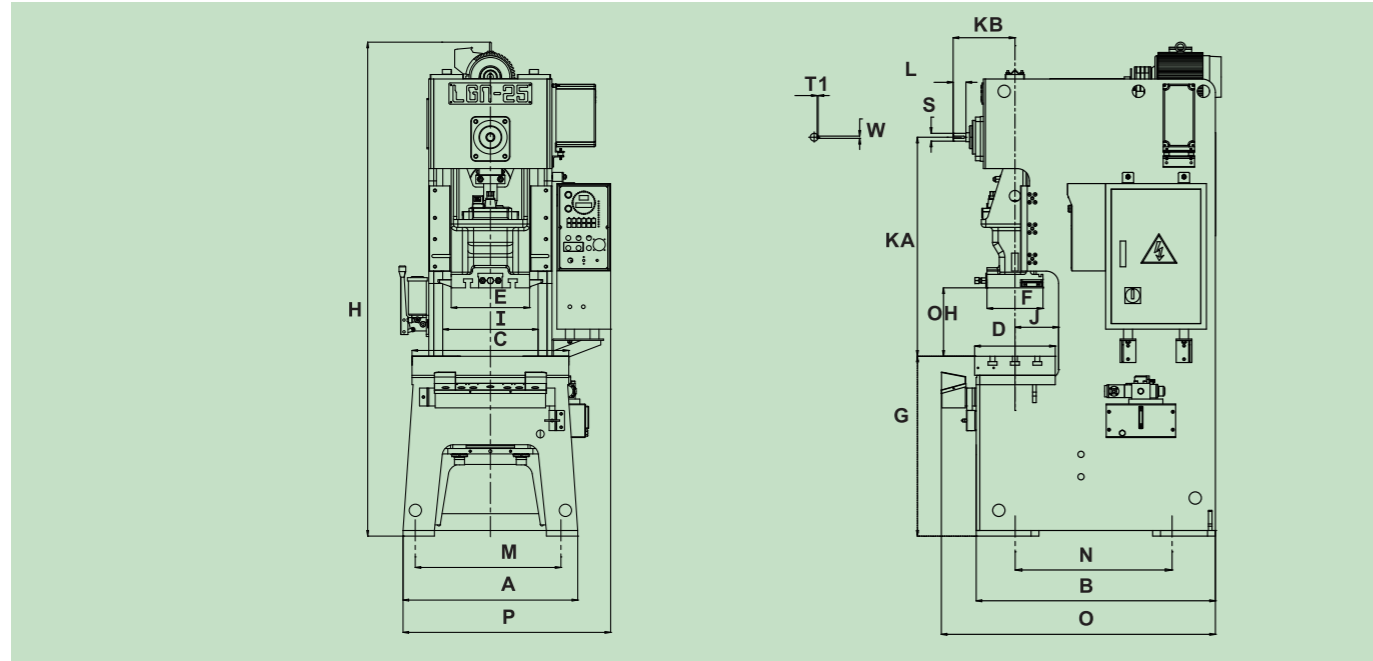

▶ 外型尺寸圖 (LGN-45~LGN-260)

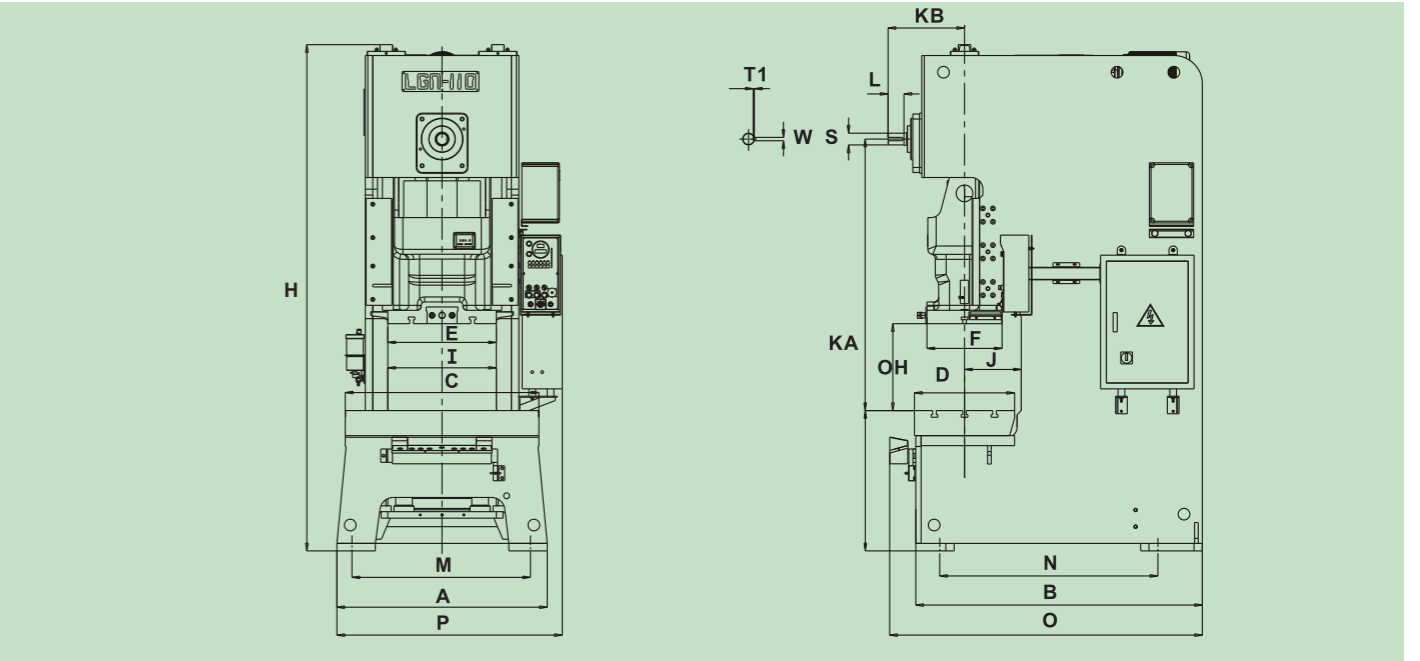

主要規格 Specification(LGN25~LGN80)

型式 Model	LGN-25		LGN-45		LGN-60		LGN-80		
	S	H	S	H	S	H	S	H	
噸數 Capacity Tons	25	45	60	80					
行程 Length of strokes mm	75	40	90	50	120	55	150	60	
行程數 Strokes per minute	定速 Fixed speed S.P.M.	100	120	80	100	70	90	60	0
	變數 Variable speed S.P.M.	100-110	120-170	80-95	100-150	70-85	90-140	60-75	80-130
能力發生點 Rated tonnage point(B.D.C) mm	3.2	1.6	3.2	1.6	3.2	2.3	4	3.2	
最大模高 Die height mm	230	247	280	300	300	332	330	375	
滑塊調整量 Adjustment of slide mm	60	60	70	80					
滑塊面積 Area of slide (ExF)mm	350x250	400x300	480x350	530x400					
台盤面積 Area of bolster(L.R.xF.B.) (CxD)mm	700x360	800x440	870x500	970x500					
台盤厚度 Thickness of bolster mm	85	110	120	130					
送料軸端長度 Length of power take off shaft (L)mm	57	60	60	60					
送料軸端直徑 Diameter of power take off shaft (S)mm	φ 35	φ 40	φ 40	φ 40					
送料軸端鍵槽 Keyway of power take off shaft (WxT1)mm	10x4.5	10x4.5	10x4.5	10x4.5					
主馬達 Main motor	定速 Fixed speed Hp x P	3x4	3x4	5x4	7.5x4				
	變數 Variable speed Hp x P	V.S.5x4	V.S.5x4	V.S.7.5x4	V.S.10x4				
滑塊調整馬達 Motor for slide adjustment Hp x P	手動(M)	1/4x4	1/2x4	1/2x4					
腳座尺寸 Foot size (AxB)mm	780x1070	880x1280	1000x1450	1100x1505					
基礎螺栓位置 Position of anchor bolts (MxN)mm	630x720	700x900	820x1050	900x1075					
總高度 Over all height (H)mm	2180	2450	2670	2845					

外型尺寸 Size of outline

	A	B	C	D	E	F	G	H	I	J	L	M	N	O	P	KA	KB	OH
LGN-25	780	1070	700	360	350	250	800	2180	426	190	80	630	720	1230	925	978	361	305
LGN-45	880	1280	800	440	400	300	800	2450	470	230	80	710	900	1470	1020	1160	402	370
LGN-60	1000	1450	870	500	480	350	810	2670	550	260	80	820	1050	1650	1140	1330	437	420
LGN-80	1100	1505	970	500	530	400	820	2845	570	260	80	900	1075	1730	1215	1425	467	480

◆各機型如有設計變更，恕難另行通知。Right of modification reserved.

主要規格 Specification(LGN110~LGN260)

型式 Model	LGN-110		LGN-160		LGN-200		LGN-260		
	S	H	S	H	S	H	S	H	
噸數 Capacity Tons	110	160	200	260					
行程 Length of strokes mm	170	70	200	80	200	90	250	100	
行程數 Strokes per minute	定速 Fixed speed S.P.M.	50	80	40	60	35	50	30	45
	變數 Variable speed S.P.M.	50-60	80-120	40-55	60-105	35-45	50-85	30-40	45-70
能力發生點 Rated tonnage point(B.D.C) mm	4	3.2	6	4	6	4	7	4	
最大模高 Die height mm	350	400	400	460	450	505	450	525	
滑塊調整量 Adjustment of slide mm	90	100	125	125					
滑塊面積 Area of slide (ExF)mm	650x450	700x500	860x650	920x700					
台盤面積 Area of bolster(L.R.xF.B.) (CxD)mm	1160x600	1350x750	1400x840	1500x860					
台盤厚度 Thickness of bolster mm	150	160	180	180					
送料軸端長度 Length of power take off shaft (L)mm	95	95	95	95					
送料軸端直徑 Diameter of power take off shaft (S)mm	φ 70	φ 70	φ 70	φ 70					
送料軸端鍵槽 Keyway of power take off shaft (WxT1)mm	20x7	20x7	20x7	20x7					
主馬達 Main motor	定速 Fixed speed Hp x P	10x4	15x4	20x4	25x4				
	變數 Variable speed Hp x P	V.S.15x4	V.S.20x4	V.S.25x4	V.S.30x4				
滑塊調整馬達 Motor for slide adjustment Hp x P	1/2x4	1x4	1x4	2x4					
腳座尺寸 Foot size (AxB)mm	1260x1715	1440x2020	1440x2180	1740x2475					
基礎螺栓位置 Position of anchor bolts (MxN)mm	1040x1255	1240x1500	1450x1610	1550x1670					
總高度 Over all height (H)mm	3170	3430	3750	4240					

外型尺寸 Size of outline

	A	B	C	D	E	F	G	H	I	J	L	M	N	O	P	KA	KB	OH
LGN-110	1260	1715	1160	600	650	450	840	3030	650	310	100	1040	1255	1940	1350	1625	515	520
LGN-160	1440	2040	1350	750	700	500	900	3430	820	385	105	1210	1500	2260	1570	1880	585	600
LGN-200	1640	2210	1400	840	860	650	1000	3750	930	430	120	1360	1640	2475	1705	2070	645	650
LGN-260	1740	2475	1500	840	920	650	1020	4240	950	430	120	1480	1895	2740	1810	2320	970	700

▶ 台盤及滑塊尺寸圖

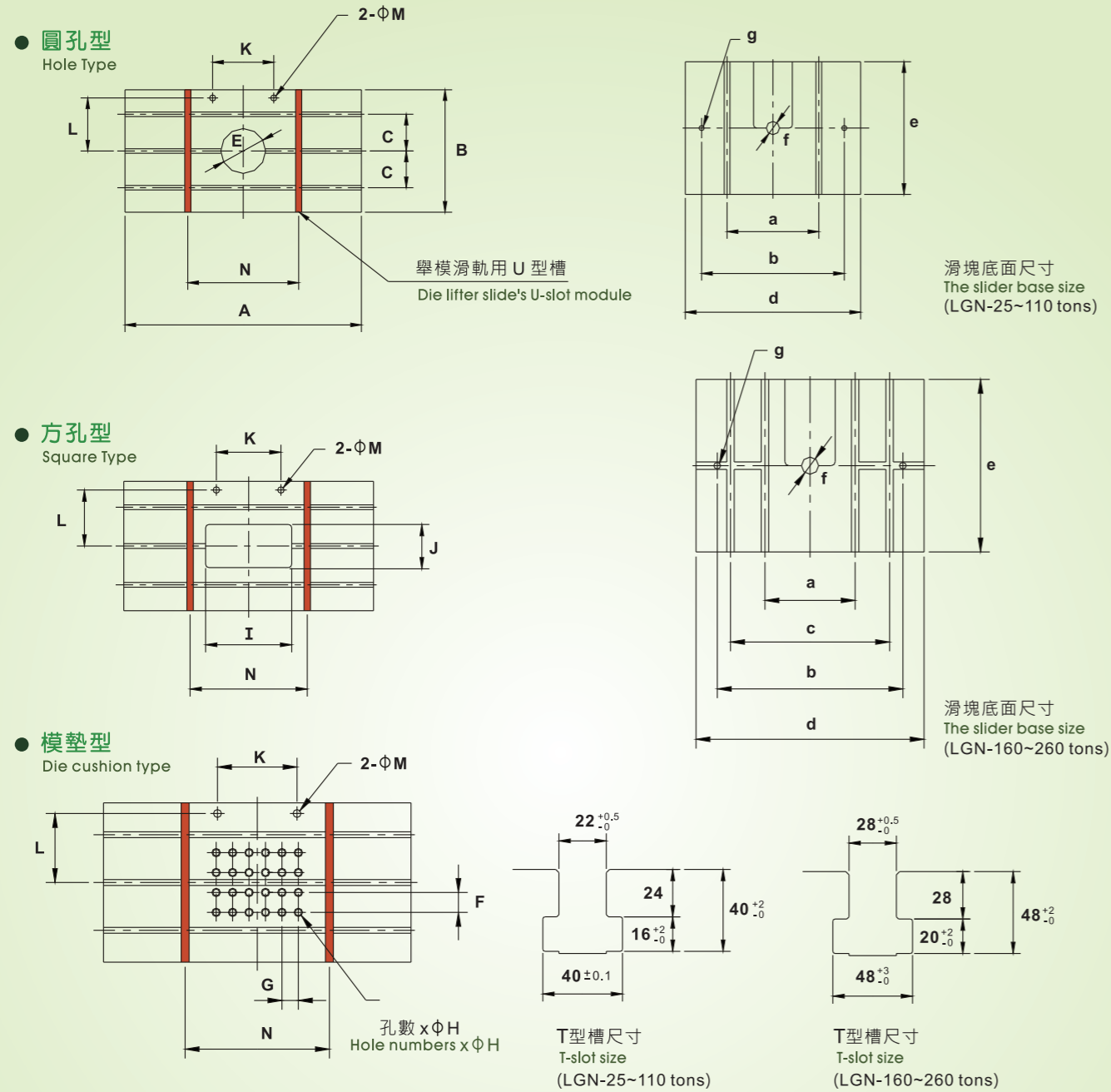

台盤及滑塊尺寸 Dimensions of bolster & slide

	A	B	C	D	E	F	G	孔數-ΦH	I	J	K	L	M	N	a	b	c	d	e	f	g
LGN-25	700	360	100	290	Φ120	37.5	50	13-Φ20	200	100	240	150	Φ22	360	200	290	-	350	250	Φ38.1	Φ23
LGN-45	800	440	120	290	Φ150	37.5	50	13-Φ20	250	120	250	185	Φ25	360	220	310	-	400	300	Φ50.8	Φ23
LGN-60	870	500	150	310	Φ175	75	62	24-Φ20	300	150	300	220	Φ30	370	300	390	-	480	350	Φ50.8	Φ23
LGN-80	970	500	150	310	Φ200	75	62	24-Φ25	360	180	300	220	Φ30	380	300	420	-	530	400	Φ50.8	Φ23
LGN-110	1160	600	180	310	Φ220	75	62	24-Φ25	400	200	300	260	Φ30	390	350	530	-	650	450	Φ50.8	Φ23
LGN-160	1350	750	220	-	Φ250	80	75	24-Φ25	440	220	400	340	Φ30	450	320	600	500	700	500	Φ65	Φ25
LGN-200	1400	840	250	-	Φ250	100	100	24-Φ25	500	250	400	380	Φ30	600	340	700	600	860	650	Φ65	Φ25
LGN-260	1500	860	250	-	Φ280	130	130	24-Φ25	520	260	500	400	Φ30	750	400	750	600	920	700	Φ65	Φ25

行程-能力曲線圖 Stroke - Capacity curve

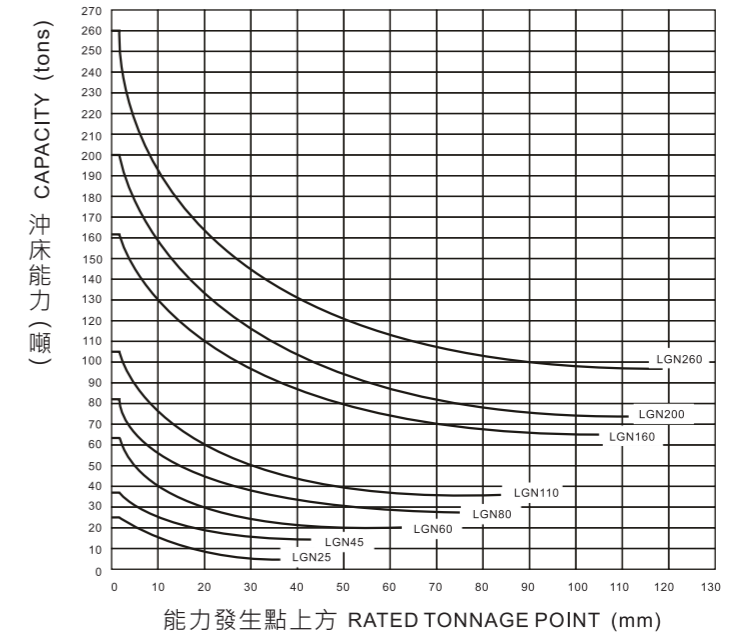

剛性特佳的沖床

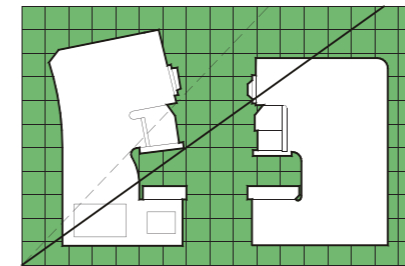

LGN系列沖床經長久沖壓作業之後，衝頭與平板間的開喉角度比傳統式衝沖床減少30%，因而能提高沖壓件之精度，延長模具之壽命。

LGN series punching machine: Through a long punching operations, the punch and the flat angle between the open throat punch reduced by 30% than traditional punching machine, which can improve the accuracy of punching and extend mold life.

長且精密的六面導軌

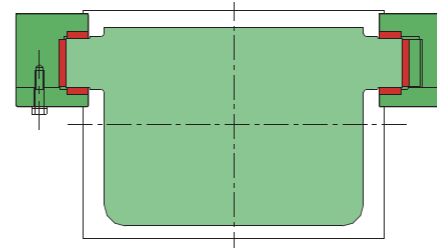

滑塊導路部位採用特殊合金銅襯片，增強承受偏心負荷，使滑塊前後左右移動變化減至最小，提高模具壽命。

Slider's guide adapts a special alloy with copper lining, increased eccentric load, so as to minimize the moving changes when the slider move around and to improve die life.

模墊 (特別附屬品) Die cushion (Optional)

機種	項目	型式 Model	能力 Capacity tons	行程 Strokes mm	模墊面積 Pad area (L.R.X.F.B.) mm	使用空壓 Air pressure required kg/cm ²
LGN-25		AC-243	2.3	60	230x190	5
LGN-45		AC-243	2.3	60	230x190	5
LGN-60		AC-303	3.6	70	350x280	5
LGN-80		AC-354	4.8	85	350x280	5
LGN-110		AC-404	6.3	90	350x280	5
LGN-160		AC-454	8	100	410x300	5
LGN-200		AC-605	14	110	560x380	5
LGN-260		AC-605	14	110	750x480	5