



立興陳機械



MACHIN

LOB 開背式 C 型沖床

OPEN BACK PRECISION POWER PRESSES  
SERIES LOB 110~300 TONS

立 興 陳 機 械

LI HSING CHEN

[www.lihsingchen.com](http://www.lihsingchen.com)



## 開背式C型沖床 SERIES LOB110~300 TONS

### ► 本機特點

- 台身採超強力鋼架結構，經消除內應力熱處理，鋼性特佳。
  - 滑塊導路長且附有氣壓式平衡裝置，運動平穩精確，衝頭底面面積大且裝模穩固，適用於連續沖模。
  - 智慧性設計，可搭配各種自動化裝置。
  - 油浴式正齒傳動裝置，噪音小、扭矩大。
  - 精度符合國家標準(CNS)1級以上。
- Machine body adapts super-strong steel body structure, eliminate internal stress by heat treatment, and the steel is particularly good.
  - Slider's guide is long and attached with the pneumatic balance device, it moves smoothly and precisely. The punch bottom area is big and stable. It is suitable for continuous punching.
  - Intelligent design, can be used with a variety of automated devices.
  - Oil bath bevel gear, small noise and big torque.
  - Precision conforms to number one national standards (CNS) level or above.

1. 曲軸角度指示器  
Crank angle indicator

2. 六面長型導軌  
Six surfaces long type guide rail

3. 模高指式器  
Die height indicator

4. 電氣控制箱  
Electrical control box

5. 光電式安全裝置(特別附屬品)  
Photoelectric safety devices (specially accessories)

6. 移動式操作盤  
Mobile operators set

7. 氣壓式模墊(特別附屬品)  
Pneumatic die cushion (specially accessories)





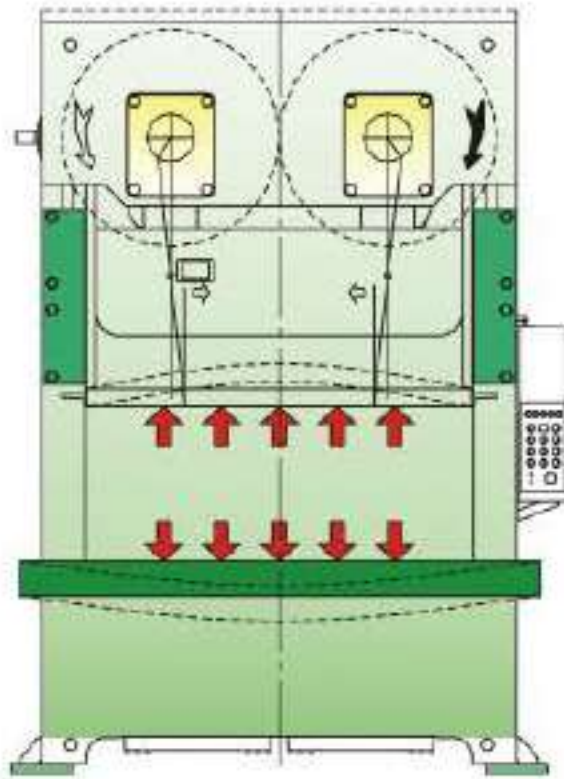

### ➔ 最小滑塊側向力

兩支曲軸反向旋轉，使滑塊之側向推力互相抵消，高剛性之滑塊及平板，減少模具不必要之咬入深度。

Two counter-rotating crankshaft, so that the lateral thrust sliders offset each other, the high rigidity of the slider and the flat, to reduce unnecessary bite into the depth of mold.

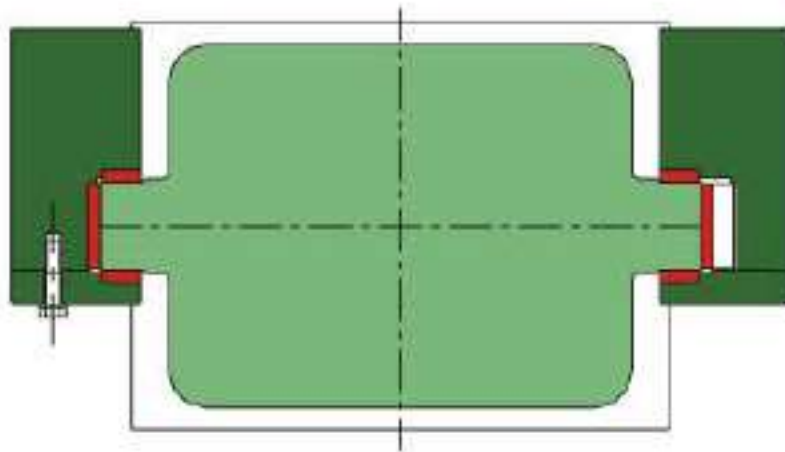

### ➔ 長且精密的六導面

滑塊導路部位採用特殊合金銅襯片，增強承受偏心負荷，使滑塊之前後左右移動變化減至最小，提高模具壽命。

Slider's guide adapts a special alloy with copper lining, increased eccentric load, so as to minimize the moving changes when the slider move around and to improve die life.

8. 油壓超負荷裝置  
Hydraulic overload device

9. 特厚壁板，鋼性特佳  
Special thick plate and the rigid is particularly good

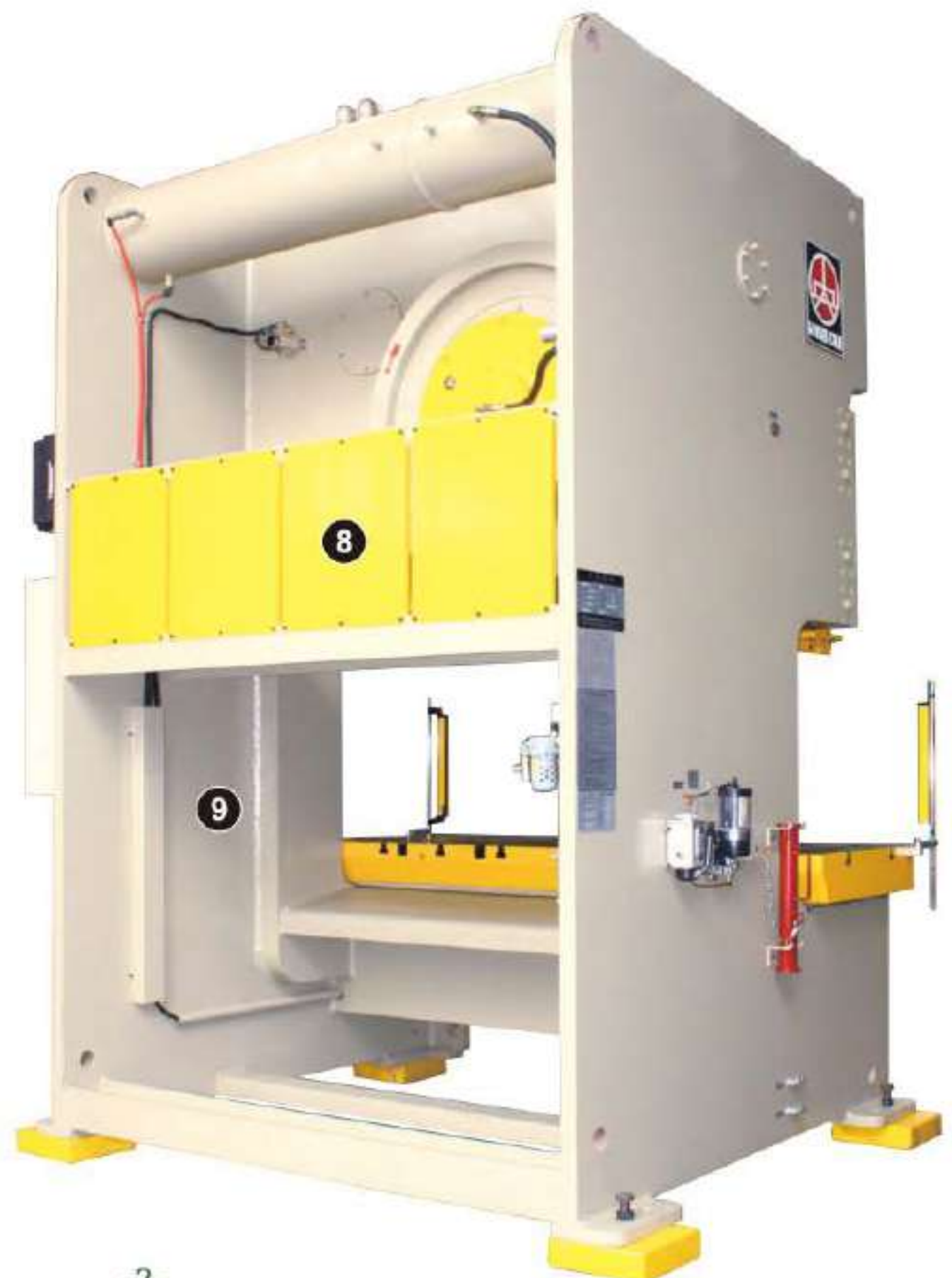



## ▶ 功能介紹



### ➔ 油壓式超負荷安全裝置 Hydraulic overload safety device

遇有超負荷情況時，滑塊運轉立即停止，確保機台及模具安全。

In the event of overload conditions, the slide stop operation immediately to ensure the safety of machine and mold.



### ➔ 雙聯閥電磁閥 Double-solenoid valve

確保沖床機械安全操作而設計，有效避免離合器異常動作。

To ensure the safe operation of punching machine to effectively prevent malfunction clutch.



### ➔ 電動模高調整裝置 Electric die height adjusting device

採用電動式模高調整裝置，並裝有上下限自動控制開關，最小調整量能達0.1mm精確位置。

With electric die height adjusting device, and equipped with upper and lower limit control switch, the minimum adjustment to the exact location of up to 0.1mm.



### ➔ 電動黃油潤滑裝置 Electric grease lubrication device

自動定時潤滑裝置，確保機台運轉順暢。

Automatic lubrication device regularly to ensure smooth running of the machine.



► 功能介紹



➔ 操作控制箱 Operation control box

人性化設計好操作，備有簡易指示螢幕可輕易排除異常問題。

Humanized design, with simple instructions and can easily eliminate abnormalities.



➔ 操作盤 Operation panel

符合安全之設計，配合簡易操作符號，使操作者更順手。

Meet with safety design, together with easy operation symbols to make the operator more comfortable.

行程-能力曲線圖 Stroke - Capacity curve

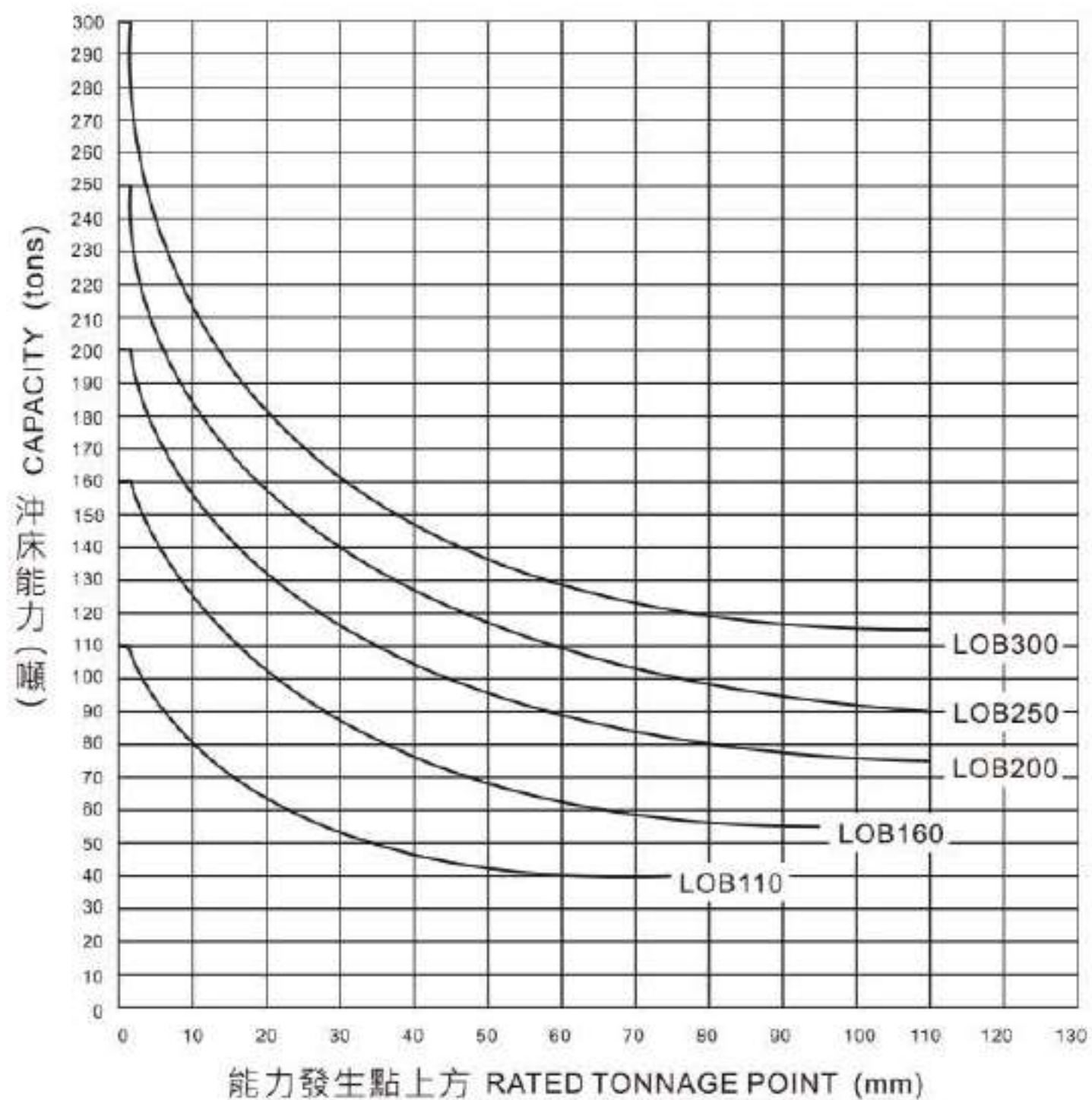



## ▶ 外型尺寸圖

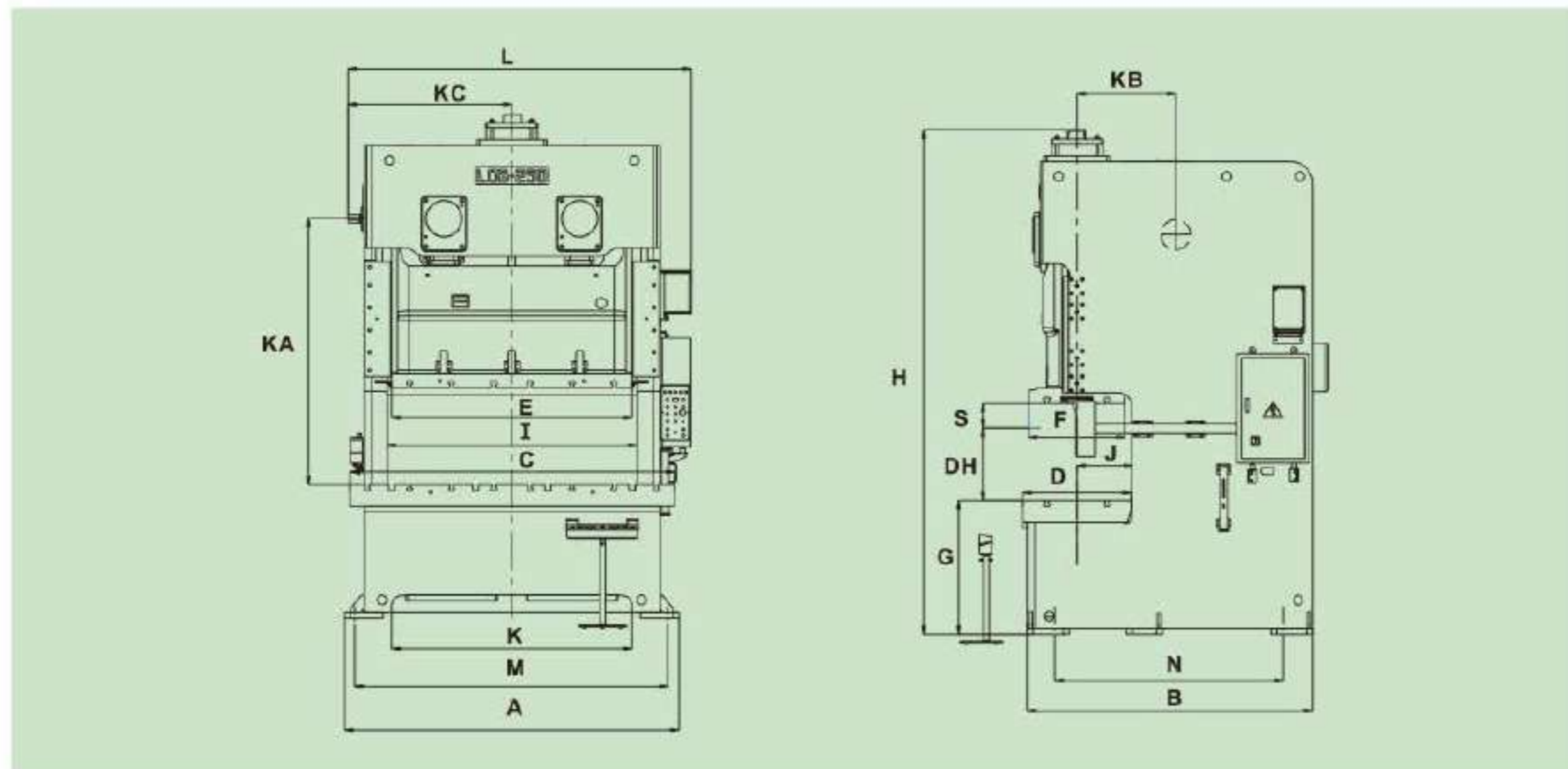

## 主要規格 Specification

型式 Model			LOB-110	LOB-160	LOB-200	LOB-250	LOB-300
噸數 Capacity	Tons		110	160	200	250	300
行程 Length of strokes	mm		150	200	250	250	300
行程數 Strokes per minute	定速 Fixed speed	S.P.M.	45	40	35	30	25
	變數 Variable speed	S.P.M.	35~60	30~50	25~45	20~40	20~35
能力發生點 Rated tonnage point(B.D.C)	mm		5	5	7	7	7
最大模高 Die height	mm		400	450	500	550	550
滑塊調整量 Adjustment of slide	mm		100	100	120	120	120
滑塊面積 Area of slide	(ExF)mm		1500x500	1630x580	1850x650	2000x800	2000x800
台盤面積 Area of bolster(L.R.xF.B.)	(CxD)mm		1920x660	2100x760	2450x850	2700x900	2800x950
台盤厚度 Thickness of bolster	mm		130	150	170	180	200
送料軸端長度 Length of power take off shaft	mm		65	100	100	100	100
送料軸端直徑 Diameter of power take off shaft	mm		φ 60	φ 65	φ 65	φ 65	φ 65
送料軸端鍵槽 Keyway of power take off shaft	mm		15x5	18x6	18x6	18x6	18x6
主馬達 Main motor	定速 Fixed speed	Hp x P	10x4	15x4	20x4	25x4	40x4
	變數 Variable speed	Hp x P	V.S.15x4	V.S.20x4	V.S.25x4	V.S.30x4	V.S.40x4
滑塊調整馬達 Motor for slide adjustment	Hp x P		1x4	2x4	3x6	3x6	3x6
使用空氣壓力 Air pressure required	kg/cm <sup>2</sup>		5	5	5	5	5

## 外型尺寸 Size of outline

	A	B	C	D	E	F	G	H	I	J	K	L	M	N	S	DH	KA	KB	KC
LOB-110	2120	1834	1920	660	1500	500	895	3225	1630	340	1580	2273	2000	1334	150	400	1685	590	1073
LOB-160	2260	2005	2100	760	1630	580	940	3350	1740	390	1620	2413	2140	1505	200	450	1805	655	1143
LOB-200	2535	2243	2450	850	1850	650	1030	3930	1945	435	1800	2668	2395	1683	250	500	1985	740	1270
LOB-250	2780	2395	2700	900	2000	800	1100	4150	2080	460	2000	2853	2560	1825	250	550	2190	820	1363
LOB-300	2860	2450	2800	950	2000	800	1120	4390	2090	485	2000	2933	2640	1900	300	550	2350	942	1403



▶ 台盤及滑塊尺寸圖

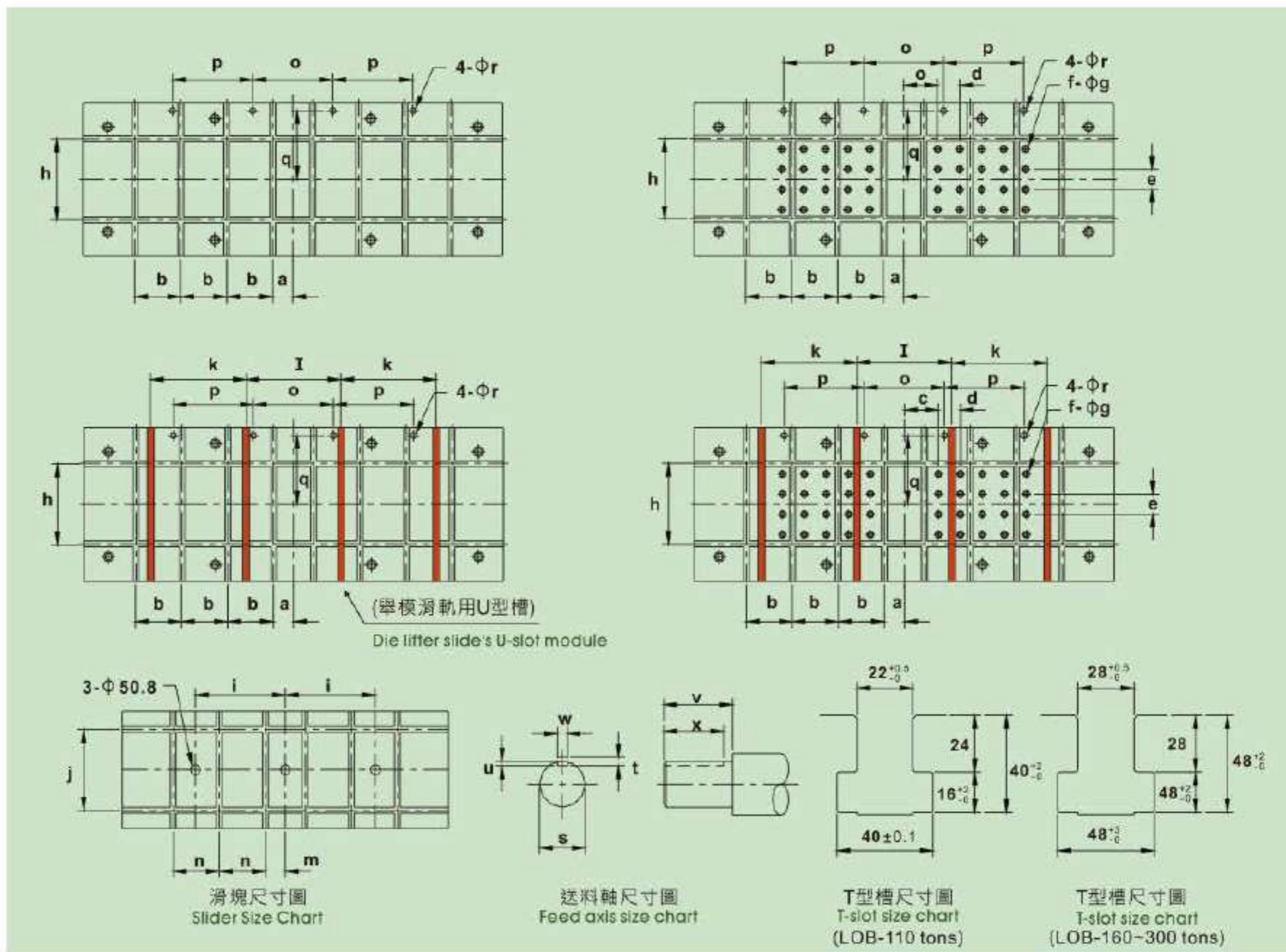

台盤及滑塊尺寸 Dimensions of bolster & slide

	a	b	c	d	e	f	g	h	i	j	k	l	m	n	o	p	q	r	s	t	u	v	w	x
LOB-110	100	210	140	110	100	40	φ25.4	300	352	300	450	390	100	210	340	300	300	30	φ60	10	5	65	15	83
LOB-160	100	230	170	110	100	40	φ25.4	400	450	400	500	430	100	230	400	400	340	30	φ65	12	6	100	18	95
LOB-200	150	300	200	100	100	40	φ32	400	440	400	420	500	150	300	400	400	380	30	φ65	12	6	100	18	95
LOB-250	150	350	250	100	100	70	φ32	500	564	500	700	600	150	350	500	500	400	30	φ65	12	6	100	18	95
LOB-300	150	350	250	100	80	60	φ32	500	564	500	700	600	150	350	500	500	425	30	φ65	12	6	100	18	95

模墊(特別附屬品) Die cushion(Optional)

項目 Project 機種 Models	型式 Model(2sets)	能力 Capacity tons	行程 Strokes mm	模墊面積 Pad area (L.R.XF.B.) mm	使用空壓 Air pressure required Kg/cm <sup>2</sup>
LOB-110	AC-404	6.3x2	90	450x350x2	5
LOB-160	AC-454	8x2	110	450x350x2	5
LOB-200	AC-504	10x2	110	450x350x2	5
LOB-250	AC-605	14x2	110	550x380x2	5
LOB-300	AC-605	14x2	150	550x380x2	5



## 附屬品介紹

### 標準附屬品

1. 濕式剎車離合器
2. 油壓式超負荷裝置
3. 電動黃油潤滑裝置
4. 滑塊及模具平衡裝置
5. 電動式滑塊調整裝置
6. 模高指示器
7. 曲軸角度指示器
8. 電子式計數器
9. 防震腳
10. 維護工具

### 特別附屬品

1. 變頻器/無段變速馬達
2. 光電式安全裝置
3. 氣壓式模墊
4. 滑塊頂料裝置
5. 自動送料軸端
6. 快速換模裝置
7. 負荷顯示器
8. 自動化機械手
9. 自動移送裝置

### STANDARD ACCESSORIES

1. Wet clutch & brake
2. Hydraulic overload protector
3. Electrical grease lubrication system
4. Slide & die balancer
5. Electrical slide adjustment device
6. Die height indicator
7. Crank angle indicator
8. Preset counter
9. Rubber mounts
10. Maintenance tool

### OPTIONAL ACCESSORIES

1. Inverter/Variable speed moter
2. Photoelectric safety device
3. Pneumatic die cushion
4. Slide knockout device
5. Power take off shaft
6. Quick die change system(Q.D.C.)
7. Load monitor
8. Robot of automatism
9. Automatic transfer device



立興陳機械

**立興陳機械廠股份有限公司**

**LI HSING CHEN MACHINE TOOL CO., LTD.**

總公司 / 新北市土城區土城工業區民權街8號

Head Office & Factory/

No 8, Min Chuan St., Tu Cheng Industrial Zone,  
Tu Cheng Dist, New Taipei City, Taiwan

Tel:886-2-2267-1118(Rep.) Fax:886-2-2267-1277

<http://www.lihsingchen.com>

E-mail:lihsingc@ms15.hinet.net

AGENTS: